

# Caster Add-On to Adjustable Height Floor Standing Barrier

ASSEMBLY INSTRUCTIONS

READ ALL INSTRUCTIONS BEFORE YOU BEGIN. DO NOT JUMP AHEAD OF ANY STEP.

## PARTS LIST:



Locking Caster  
(4 pcs)

Add-On Kit to be used with  
Adjustable Height Floor Standing Barriers

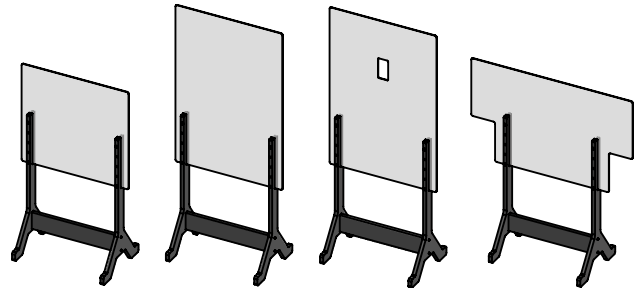

14100

14101

14102

14103

\*NO TOOLS REQUIRED

\*TWO PERSON ASSEMBLY RECOMMENDED

**STEP 1:** If clear acrylic Divider Panel is currently installed in your Floor Standing Barrier, unscrew and remove Panel from Legs and place it off to the side.

**STEP 2:** Carefully tilt back the Leg assembly of your Floor Standing Barrier and lay it down on a flat surface. Take one of the supplied casters and push stem of Caster into one of the sockets in the bottom of the Legs until fully inserted. **Lock the brake on caster once installed.** Insert remaining Locking Casters into other 3 sockets, again making sure to lock the brake on each caster once installed.

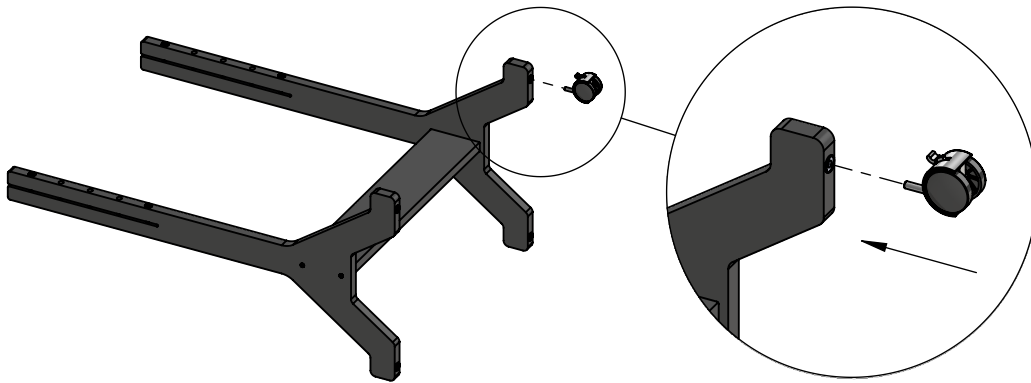

**STEP 3:** Carefully tilt your Floor Standing Barrier back up straight until all 4 casters are firmly seated on flat surface. Re-install Divider Panel into Leg assembly of Floor Standing Barrier.



Set of 4 Casters Kit  
14112

**STEP 4:** Unlock brakes on casters to move your Barrier around freely. Once your Floor Standing Barrier is in its desired location, lock all 4 casters by pressing down on the brakes.

## ASSEMBLY COMPLETED